



Circuit breaker size S00 for motor protection, CLASS 10 A-release 5.5...8 A N-release 104 A Screw terminal Standard switching capacity

<b>product brand name</b>	SIRIUS
<b>product designation</b>	Circuit breaker
<b>design of the product</b>	For motor protection
<b>product type designation</b>	3RV1
<b>General technical data</b>	
<b>size of the circuit-breaker</b>	S00
<b>size of contactor can be combined company-specific</b>	S00
product extension auxiliary switch	Yes
<b>power loss [W] for rated value of the current</b>	
• at AC in hot operating state	9.25 W
• at AC in hot operating state per pole	3.1 W
insulation voltage with degree of pollution 3 at AC rated value	690 V
<b>surge voltage resistance rated value</b>	6 kV
<b>mechanical service life (operating cycles)</b>	
• of the main contacts typical	100 000
• of auxiliary contacts typical	100 000
electrical endurance (operating cycles) typical	100 000
<b>reference code according to IEC 81346-2</b>	Q
<b>Substance Prohibition (Date)</b>	01/01/2013
<b>Weight</b>	0.282 kg
<b>Ambient conditions</b>	
installation altitude at height above sea level maximum	2 000 m
<b>ambient temperature</b>	
• during operation	-20 ... +60 °C
• during storage	-50 ... +80 °C
• during transport	-50 ... +80 °C
relative humidity during operation	10 ... 95 %
<b>Main circuit</b>	
<b>number of poles for main current circuit</b>	3
<b>adjustable current response value current of the current-dependent overload release</b>	5.5 ... 8 A
<b>type of voltage for main current circuit</b>	AC
<b>operating voltage</b>	
• rated value	20 ... 690 V
• at AC-3 rated value maximum	690 V
• at AC-3e rated value maximum	690 V
<b>operating frequency rated value</b>	50 ... 60 Hz
<b>operational current rated value</b>	8 A
<b>operational current</b>	
• at AC-3 at 400 V rated value	8 A

<ul style="list-style-type: none"> <li>● at AC-3e at 400 V rated value</li> </ul>	8 A
<b>operating power</b>	
<ul style="list-style-type: none"> <li>● at AC-3 <ul style="list-style-type: none"> <li>— at 230 V rated value</li> <li>— at 400 V rated value</li> <li>— at 500 V rated value</li> <li>— at 690 V rated value</li> </ul> </li> <li>● at AC-3e <ul style="list-style-type: none"> <li>— at 230 V rated value</li> <li>— at 400 V rated value</li> <li>— at 500 V rated value</li> <li>— at 690 V rated value</li> </ul> </li> </ul>	1.5 kW 3 kW 4 kW 5.5 kW  1.5 kW 3 kW 4 kW 5.5 kW
<b>operating frequency</b>	
<ul style="list-style-type: none"> <li>● at AC-3 maximum</li> <li>● at AC-3e maximum</li> </ul>	15 1/h 15 1/h

#### Auxiliary circuit

<b>type of voltage for auxiliary and control circuit</b>	AC/DC
<b>number of NC contacts for auxiliary contacts</b>	0
<b>number of NO contacts for auxiliary contacts</b>	0
number of CO contacts for auxiliary contacts	0

#### Protective and monitoring functions

<b>product function</b>	
<ul style="list-style-type: none"> <li>● ground fault detection</li> <li>● phase failure detection</li> </ul>	No Yes
<b>trip class</b>	CLASS 10
<b>design of the overload release</b>	thermal
<b>maximum short-circuit current breaking capacity (I<sub>cu</sub>)</b>	
<ul style="list-style-type: none"> <li>● at AC at 240 V rated value</li> <li>● at AC at 400 V rated value</li> <li>● at AC at 500 V rated value</li> <li>● at AC at 690 V rated value</li> </ul>	100 kA 50 kA 3 kA 2 kA
<b>operating short-circuit current breaking capacity (I<sub>cs</sub>) at AC</b>	
<ul style="list-style-type: none"> <li>● at 240 V rated value</li> <li>● at 400 V rated value</li> <li>● at 500 V rated value</li> <li>● at 690 V rated value</li> </ul>	100 kA 12.5 kA 3 kA 2 kA
response value current of instantaneous short-circuit trip unit	104 A

#### UL/CSA ratings

<b>full-load current (FLA) for 3-phase AC motor</b>	
<ul style="list-style-type: none"> <li>● at 480 V rated value</li> <li>● at 600 V rated value</li> </ul>	8 A 8 A
<b>yielded mechanical performance [hp]</b>	
<ul style="list-style-type: none"> <li>● for single-phase AC motor <ul style="list-style-type: none"> <li>— at 110/120 V rated value</li> <li>— at 230 V rated value</li> </ul> </li> <li>● for 3-phase AC motor <ul style="list-style-type: none"> <li>— at 200/208 V rated value</li> <li>— at 220/230 V rated value</li> <li>— at 460/480 V rated value</li> <li>— at 575/600 V rated value</li> </ul> </li> </ul>	0.33 hp 1 hp  2 hp 2 hp 5 hp 5 hp

#### Short-circuit protection

<b>product function short circuit protection</b>	Yes
<b>design of the short-circuit trip</b>	magnetic
<b>design of the fuse link for IT network for short-circuit protection of the main circuit</b>	
<ul style="list-style-type: none"> <li>● at 240 V</li> <li>● at 400 V</li> <li>● at 500 V</li> <li>● at 690 V</li> </ul>	gG 80 A gG 63 A gG 40 A gG 40 A

#### Installation/ mounting/ dimensions

<b>mounting position</b>	any
--------------------------	-----

<b>fastening method</b>	screw and snap-on mounting onto 35 mm DIN rail according to DIN EN 60715
<b>height</b>	90 mm
<b>width</b>	45 mm
<b>depth</b>	75 mm
<b>required spacing</b>	
<ul style="list-style-type: none"> <li>● for grounded parts at 400 V <ul style="list-style-type: none"> <li>— downwards 20 mm</li> <li>— upwards 20 mm</li> <li>— at the side 9 mm</li> </ul> </li> <li>● for live parts at 400 V <ul style="list-style-type: none"> <li>— downwards 20 mm</li> <li>— upwards 20 mm</li> <li>— at the side 9 mm</li> </ul> </li> <li>● for grounded parts at 500 V <ul style="list-style-type: none"> <li>— downwards 20 mm</li> <li>— upwards 20 mm</li> <li>— at the side 9 mm</li> </ul> </li> <li>● for live parts at 500 V <ul style="list-style-type: none"> <li>— downwards 20 mm</li> <li>— upwards 20 mm</li> <li>— at the side 9 mm</li> </ul> </li> <li>● for grounded parts at 690 V <ul style="list-style-type: none"> <li>— downwards 20 mm</li> <li>— upwards 20 mm</li> <li>— backwards 0 mm</li> <li>— at the side 9 mm</li> <li>— forwards 0 mm</li> </ul> </li> <li>● for live parts at 690 V <ul style="list-style-type: none"> <li>— downwards 20 mm</li> <li>— upwards 20 mm</li> <li>— backwards 0 mm</li> <li>— at the side 9 mm</li> <li>— forwards 0 mm</li> </ul> </li> </ul>	
<b>Connections/ Terminals</b>	
<b>type of electrical connection</b>	
<ul style="list-style-type: none"> <li>● for main current circuit</li> </ul>	screw-type terminals
<b>arrangement of electrical connectors for main current circuit</b>	Top and bottom
<b>type of connectable conductor cross-sections</b>	
<ul style="list-style-type: none"> <li>● for main contacts <ul style="list-style-type: none"> <li>— solid or stranded 2x (0,5 ... 1,5 mm<sup>2</sup>), 2x (0,75 ... 2,5 mm<sup>2</sup>), 2x (1 ... 4 mm<sup>2</sup>)</li> <li>— finely stranded with core end processing 2x (0.5 ... 1.5 mm<sup>2</sup>), 2x (0.75 ... 2.5 mm<sup>2</sup>)</li> </ul> </li> </ul>	
<b>type of connectable conductor cross-sections</b>	
<ul style="list-style-type: none"> <li>● for auxiliary contacts <ul style="list-style-type: none"> <li>— solid or stranded 2x (0.5 ... 1.5 mm<sup>2</sup>), 2x (0.75 ... 2.5 mm<sup>2</sup>)</li> </ul> </li> </ul>	
<b>tightening torque</b>	
<ul style="list-style-type: none"> <li>● for main contacts with screw-type terminals 0.8 ... 1.2 N·m</li> <li>● for auxiliary contacts with screw-type terminals 0.8 ... 1.2 N·m</li> </ul>	
<b>design of screwdriver shaft</b>	Diameter 5 to 6 mm
<b>size of the screwdriver tip</b>	Pozidriv size 2
<b>design of the thread of the connection screw</b>	
<ul style="list-style-type: none"> <li>● for main contacts M3</li> </ul>	
<b>Safety related data</b>	
product function suitable for safety function	Yes
<b>suitability for use</b>	
<ul style="list-style-type: none"> <li>● safety-related switching on No</li> <li>● safety-related switching OFF Yes</li> </ul>	
<b>service life maximum</b>	10 a
<b>test wear-related service life necessary</b>	Yes
<b>proportion of dangerous failures</b>	
<ul style="list-style-type: none"> <li>● with low demand rate according to SN 31920 40 %</li> </ul>	

• with high demand rate according to SN 31920	50 %
<b>B10 value with high demand rate according to SN 31920</b>	5 000
<b>failure rate [FIT] with low demand rate according to SN 31920</b>	50 FIT
<b>ISO 13849</b>	
<b>device type according to ISO 13849-1</b>	3
<b>overdimensioning according to ISO 13849-2 necessary</b>	Yes
<b>IEC 61508</b>	
<b>safety device type according to IEC 61508-2</b>	Type A
<b>Electrical Safety</b>	
<b>protection class IP on the front according to IEC 60529</b>	IP20
<b>touch protection on the front according to IEC 60529</b>	finger-safe, for vertical contact from the front
<b>Display</b>	
display version for switching status	Rocker switch
<b>Approvals Certificates</b>	
<b>General Product Approval</b>	



[KC](#)



<b>General Product Approval</b>	<b>For use in hazardous locations</b>	<b>Test Certificates</b>	<b>Maritime application</b>
---------------------------------	---------------------------------------	--------------------------	-----------------------------



[Type Test Certificates/Test Report](#)

[Special Test Certificate](#)



**Maritime application**



<b>other</b>	<b>Railway</b>	<b>Environment</b>
--------------	----------------	--------------------

[Confirmation](#)



[Miscellaneous](#)



[Special Test Certificate](#)

[Environmental Confirmations](#)

**Further information**

Information on the packaging

<https://support.industry.siemens.com/cs/ww/en/view/109813875>

Information- and Downloadcenter (Catalogs, Brochures,...)

<https://www.siemens.com/ic10>

Industry Mall (Online ordering system)

<https://mall.industry.siemens.com/mall/en/en/Catalog/product?mlfb=3RV1011-1HA10>

Cax online generator

<http://support.automation.siemens.com/WW/CAXorder/default.aspx?lang=en&mlfb=3RV1011-1HA10>

Service&Support (Manuals, Certificates, Characteristics, FAQs,...)

<https://support.industry.siemens.com/cs/ww/en/ps/3RV1011-1HA10>

Image database (product images, 2D dimension drawings, 3D models, device circuit diagrams, EPLAN macros, ...)

[http://www.automation.siemens.com/bilddb/cax\\_de.aspx?mlfb=3RV1011-1HA10&lang=en](http://www.automation.siemens.com/bilddb/cax_de.aspx?mlfb=3RV1011-1HA10&lang=en)

Characteristic: Tripping characteristics, I<sup>2</sup>t, Let-through current

<https://support.industry.siemens.com/cs/ww/en/ps/3RV1011-1HA10/char>

Further characteristics (e.g. electrical endurance, switching frequency)

<http://www.automation.siemens.com/bilddb/index.aspx?view=Search&mlfb=3RV1011-1HA10&objecttype=14&gridview=view1>

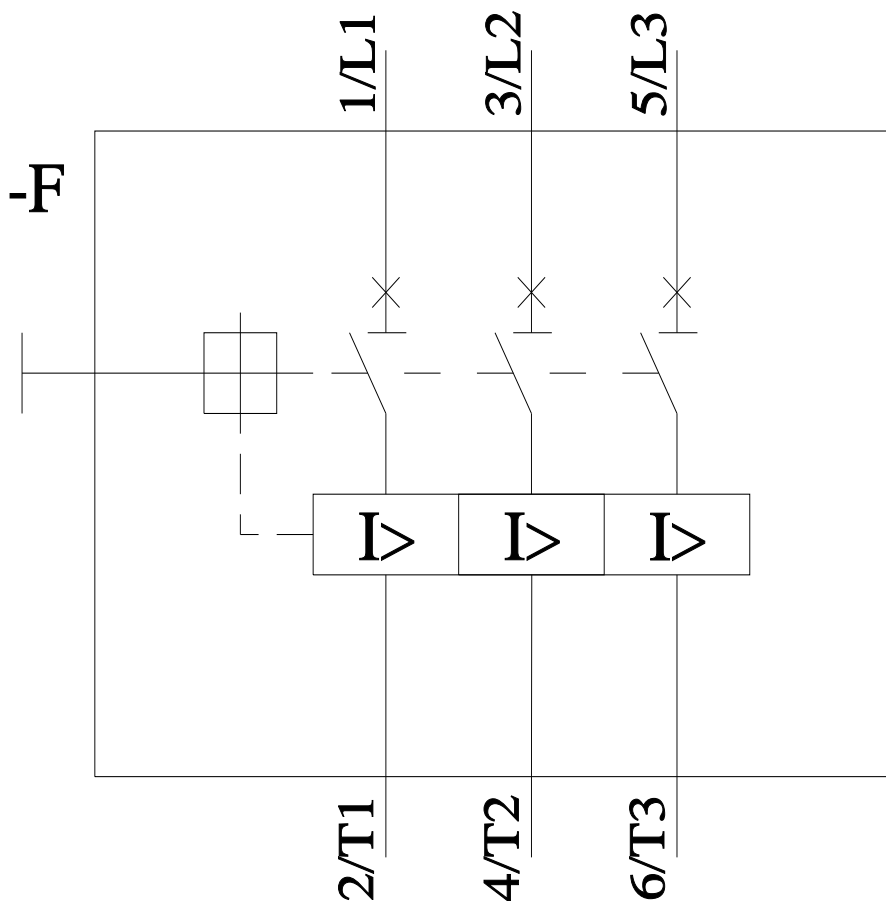
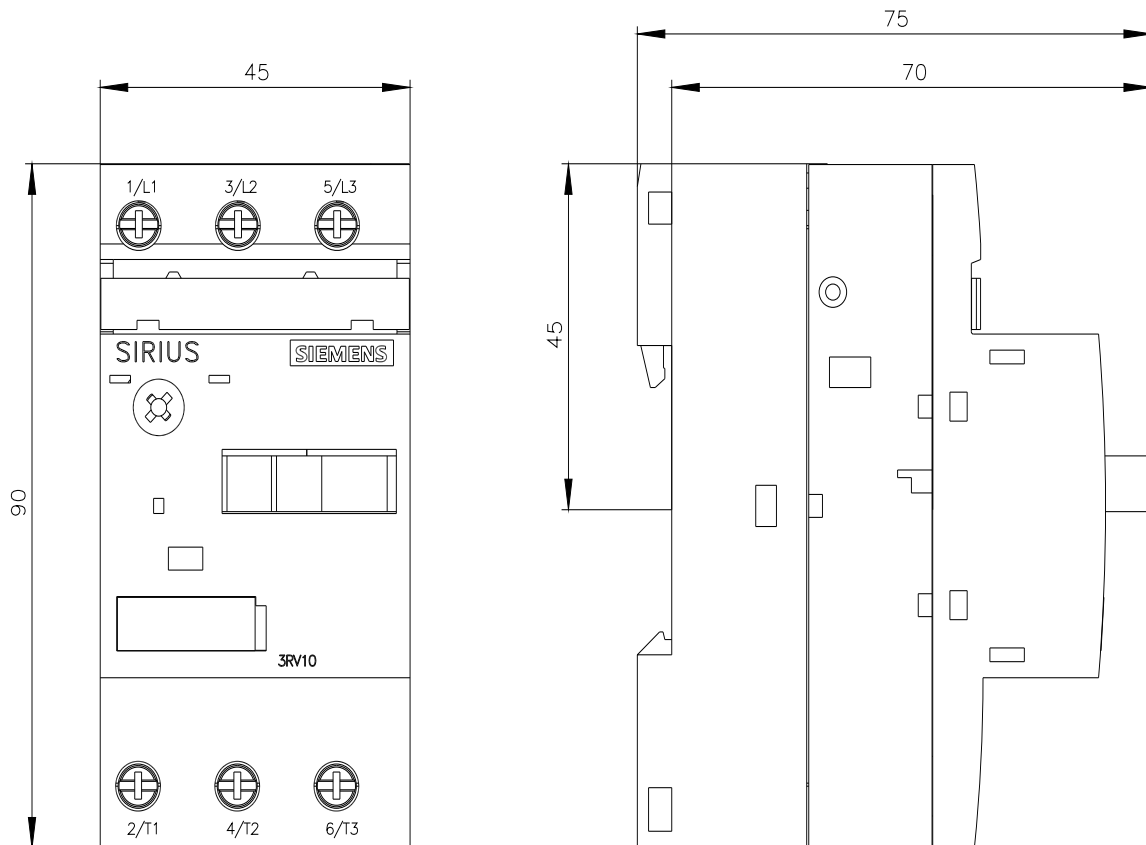

last modified:

6/11/2025

